

## HOW TO INSTALL THE ROOF EXHAUST UNITS MODEL CT-4, CT-6 & CT-10

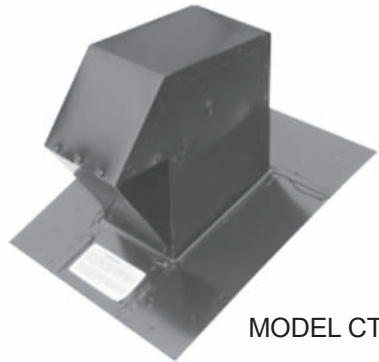

MODEL CT-4

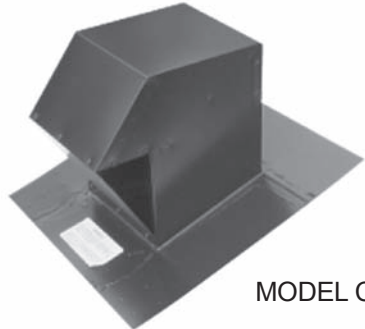

MODEL CT-6

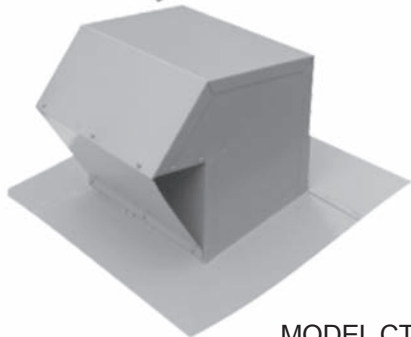

MODEL CT-10

**STEP 1**

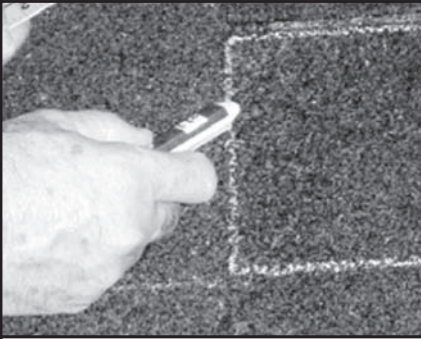

Determine the location of the exhaust vent. (no lower than 5' from the eaves) and inspect the attic to determine the location of the rafters and centre the hole between the rafters.  
Using chalk and ruler, outline the size of the hole required over the shingles or sheathing.

**STEP 2**

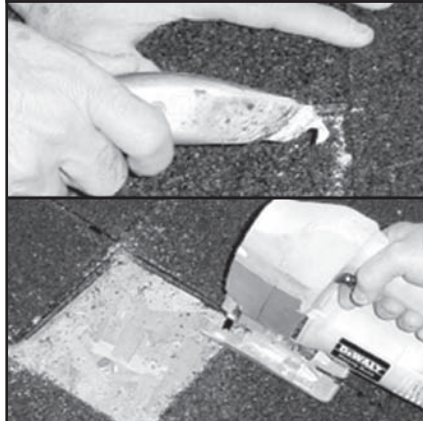

Using a sharp knife, cut away the shingles, then cut through shingles using a jigsaw. Carefully remove the roofing nails within 12" of the hole.

**STEP 3**



Install adjustable tubing onto the collar of roof exhaust unit and secure with a good quality duct tape.

**STEP 4**



Overlap plastic barrier over insulation and push insulation all the way down into the unit insulating collar complete. Secure with duct tape.

**STEP 5**



Apply a generous amount of roofing cement 4" wide around perimeter of hole. Slide insulating tubing down into hole followed by roof exhaust unit making sure flange of unit is totally embedded in the roofing cement. Nail or screw unit onto sheathing spacing them 4" around perimeter of flange and 1" from the edge. Apply a generous amount of roofing cement over the back, and halfway down both sides of the flange.

**STEP 6**



Apply a generous amount of roofing cement on top of flange back and halfway down on each side.  
Nail shingles into place. Finish by installing a bead of caulking around flange, sealing all joints.